



A TEREX BRAND

PRODUCT SPECIFICATION

6800CT

HORIZONTAL
GRINDER



WHOLE TREES • STORM DEBRIS • SLASH • STUMPS • REGRIND

KEY FEATURES...

The CBI Magnum Force 6800CT Horizontal Grinder is engineered to surpass every horizontal grinder that came before it. Once land clearing and wood waste professionals switch to CBI grinders for their ultimate production, performance, and durability, they never look back.

Improving on the 6800BT's revolutionary design, the 6800CT has a 15 percent larger screening area, wrapping more than 190° around the rotor, allowing production rates to surge beyond 200 tons an hour. Supported by a larger shaft and bearings and an optional 1200hp CAT C32, the engine powers the forged drum rotor through the toughest materials. The design of CBI's offset helix rotor minimizes energy loss from each strike and distributes material evenly across the 24 hammers, requiring less power while outproducing the competition. Built from a fully welded steel frame and reinforced heavy-duty weldments, this yellow monster processes land clearing debris, pallets, clean industrial waste, stumps, logs, mulch, bark, shingles, and whole trees as fast as it can be loaded, producing valuable end-products and giving operators command over real world job deadlines.

Ensuring the best fuel economy and the lowest possible cost per ton, CBI's user friendly interface displays simplified information for controls and monitoring. Operators can adjust and save multiple groups of feed speeds, pressures, and automated control systems to guarantee the most efficient performance across a wide range of materials. Speed sensors have been added to the feed system for a continuous and efficient pace of grinding. Remote monitoring gives owners a detailed report of operating data, machine status, alarms, and key metrics. Users can be sent automated maintenance notices to stay proactive on service, reducing downtime and keeping the machine in peak running condition year after year.

The 6800CT is designed for superior performance across all phases of the operation, including machine maintenance. An expanded service area provides open access to the engine. The grinding chamber can be raised from the ground level for easy access, allowing tip and screen changes to be done in minutes out in the field. Hydraulic filters are also at the ground level, with all setup functions combined into one valve bank. Sloped decks deter accumulation of debris and covers are easily removed for service. The fuel tank has been increased to 475 gallons. A 110 gallon hydraulic tank is strategically mounted for better access while reducing strain on the 5000 PSI hydraulic pumps. The clutch has a separate tank and cooler from the main hydraulics.

Supported 24/7 by a dashboard of updated reports, technical phone support, and CBI's Field Service Engineers, there's no guesswork when it comes to keeping this machine operating at top performance. All together, no other horizontal grinder in its weight class meets the production rates or low cost of ownership like the CBI Magnum Force 6800CT Horizontal Grinder.

CHANGE SCREENS IN MINUTES



60" wide cleated discharge belt provides unrestricted discharge of ground product.

Split hog box for ease of maintenance. The entire grinding chamber rises for quick tip and screen changes.

CAT C27; 1050hp engine or optional CAT C32; 1125hp or 1200hp engine.

High-torque feed roller. Speed sensors monitor the feed system's speed in real time to maintain a continuous and efficient pace of grinding.

LARGE CAPACITY FEED HOPPER



Infeed walls wing outwards to increase loading clearance and funnel material.

Heavy-duty support gussets are 100% welded.

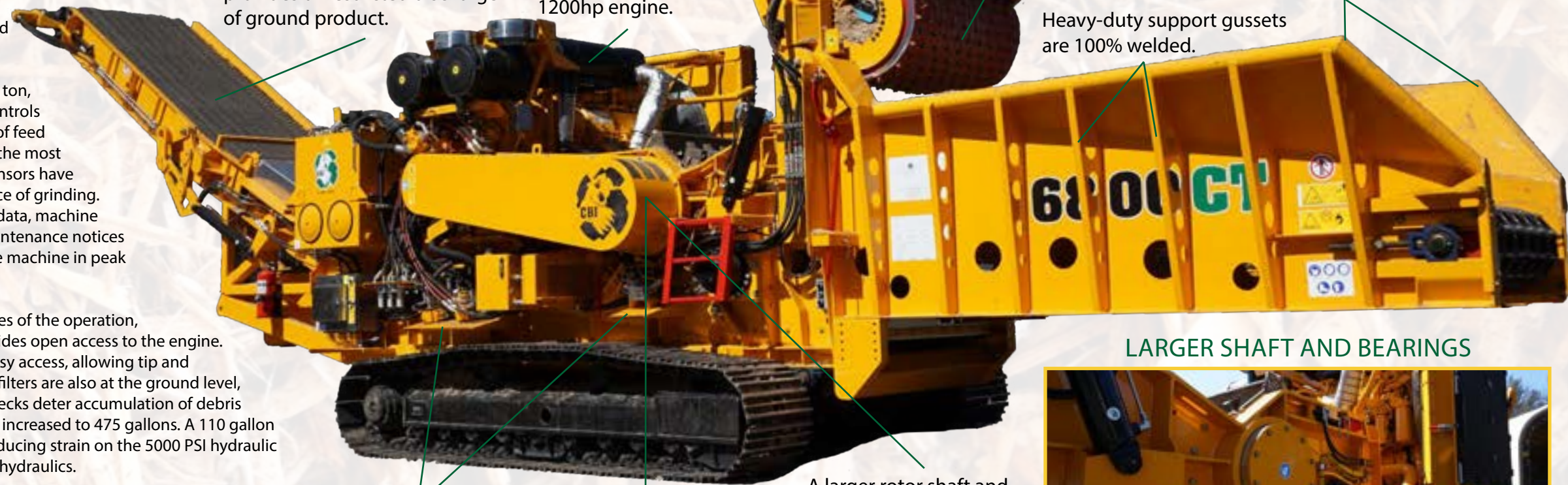

Sloped decks deter debris accumulation.

Metal Detection System (MDS) protects machine from tramp metal.

A larger rotor shaft and bearings increase bearing life and allow for a 1200hp CAT C32 engine.

LARGER SHAFT AND BEARINGS



HIGH STRENGTH ROTORS FOR HIGH PRODUCTION



The 40" diameter x 60" wide upturn rotor has a forged, thick, high-strength core with 24 weld-on hammers. The offset helix pattern cuts the full width of the rotor, distributing material across the hammers for natural efficiency. This design increases throughput over conventional, pinned, or welded hammer rotors used by our competitors. CBI's bolt-on reversible tips grind more material for less cost than any other tip. Our Replace-A-Face™ hammer system allows the end user to swap out the face independent of the rest of the hammer for quick, easy, and inexpensive maintenance.

Various hammer inserts



Hog box opens in seconds



Increased hydraulic tank capacity



Wedge lock secures upper hog box

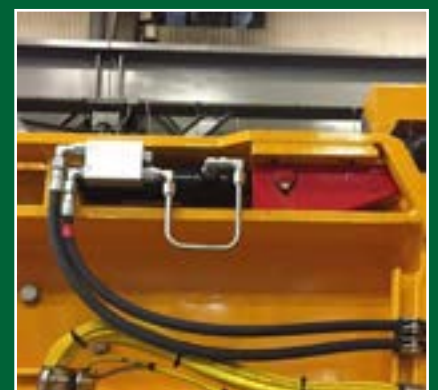

Metal Detection System (MDS)

A problem for any industrial grinder has to do with tramp metal entering the hog box and causing significant damage, which leads to downtime. The Metal Detection System™ (MDS) engages within milliseconds whenever the grinder's rotor makes contact with tramp metal. The rotor is monitored by an adjustable electronic sensor to alert the control system when tramp metal is detected. The MDS will automatically lower the engine RPM, raise the top feed roller and reverse the infeed to allow the operator to find the tramp metal. The MDS system's sensitivity can be adjusted up and down for the application, and can be precise enough to detect a bag of bolts. Pictured to the right is a CBI grinder up and running just minutes after the MDS system picked up a trailer hitch. They didn't even break a tooth.



TRANSPORT DIMENSIONS

Width: 11'-1" (3,383mm)
Height: 12'-0" (3,657mm)
Length: 43'-2" (13,159mm)
Weight: 95,000 lbs. (43,091 kg) (approx.)

DISCHARGE CONVEYOR

Width: 60" (1,524mm)
Length: 36' (10,972mm)
Height: 16' 7/16" (4,887mm)

INFEED

6 strands heavy-duty drag chain
accepts 40" material
Top Feed Roll: 40"D x 60"W
Width: 60" (1,066mm)
Length: 17'-0" (5,181mm)

ENGINE/DRIVE

CAT C27; 1050hp engine
Option - CAT C32; 1125hp or
1200hp engine

CONTROLS

Parker IQAN™
Remote control operated
Telematics

HYDRAULICS

Hydrostatic, closed loop
Hydraulic capacity 110 gallons (416 L)

FAN

Reversing pitch radiator fan that
reverses airflow automatically

FUEL TANK

475 (1798 L)

ELECTRICAL

Variable speed system

TRACKS

700mm triple grouser

ROTOR

Shaft: 8" (203mm)
Width: 60" (1,524mm)
Diameter: 40" (1,016mm)
RPMs: 1440

OPTIONS

Hydraulic regrind door
Air compressor
Overband magnet
Magnetic head pulley

Specifications subject to change without notice.
Available as tracked, tracked dolly, portable, or stationary.

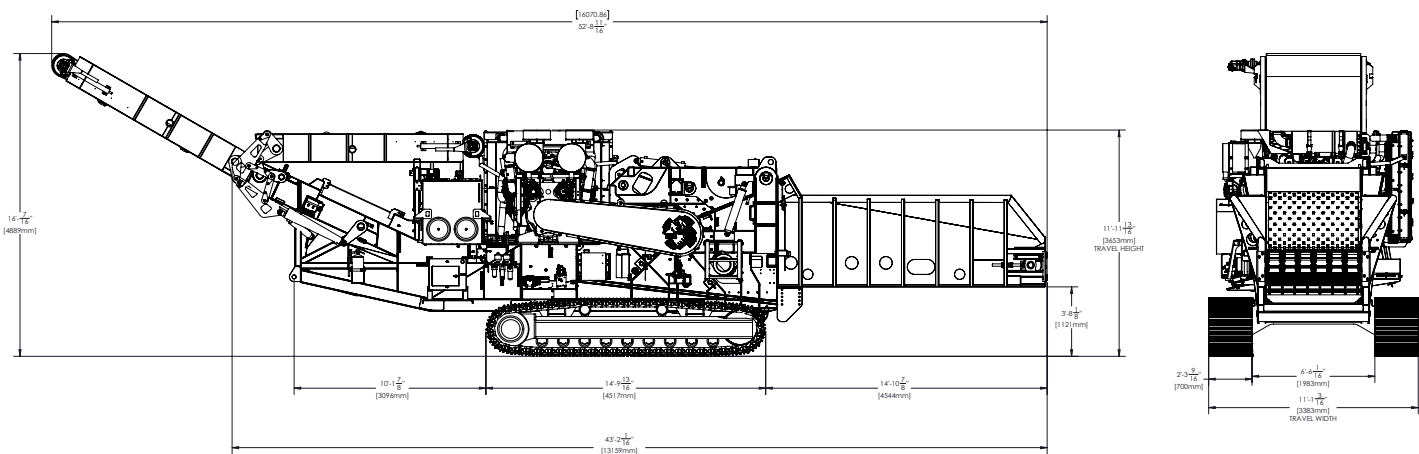

Continental Biomass Industries

World's best stationary and portable material recovery systems.

22 Whittier Street, Newton, NH, 03858
Phone: (603) 382-0556 Fax: (603) 382-0557
Web: www.terex.com/cbi Email: NWT.InfoFWD@terex.com

Distributed by: